



**TAC**  
1354 Clifford Avenue  
P. O. Box 2940  
Loves Park, IL 61132-2940  
www.tac.com

## 2218 Series

### Summer-Winter Pneumatic Room Thermostats General Instructions

## Application

The 2218 Series Pneumatic Room Thermostats are designed for proportional control of pneumatic valves and damper actuators in environmental control systems where a dual pressure air main is utilized for seasonal changeover of heating and cooling functions. Their design incorporates a highly sensitive, bimetal, thermostatic element, and a pilot-operated relay with pneumatic feedback for accuracy and stability over the entire operating range.

Indexing the thermostat from summer control (reverse acting) to winter control (direct acting), or vice versa, is accomplished by remotely changing the main air pressure supply from 16 psig (summer) to 25 psig (winter). Models are also available that operate on slightly different pressures to replace many competitive devices.

These thermostats have a serrated thumb wheel for setpoint adjustment. Models are also available with preassembled internal dial stops. Thermostat covers are available in various styles to meet particular requirements. Cover options include models with a setpoint scale and a thermometer, a setpoint scale only, a thermometer only, or blank. An external setpoint adjustment cover is available on some models, or can be field-installed on covers where desired.

## Features

- Factory-calibrated, stainless steel ball-in-seat provides pneumatic feedback for stable, linear operation.
- Snap-acting (not gradual) changeover from direct action to reverse action operation and vice versa.
- Easy-to-use throttling range adjustment and recalibration.
- Adjustable (patented) bimetal shows actual throttling range in both °F and °C. Adjustable 2 to 12 °F (1 to 6.7 °C).
- Leak-proof, self-closing branch gauge tap.

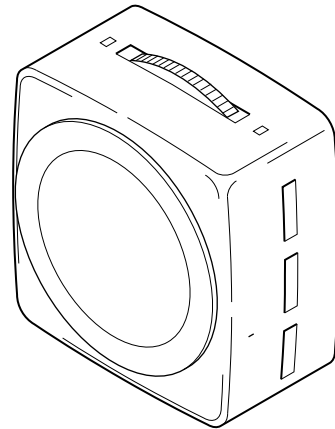

Full Dial Cover Shown  
(Covers must be ordered separately except as noted.)

## SPECIFICATIONS

**Action:** Proportional.

**Setpoint Range:** See Table-1 and Table-2.

**Throttling Range:** See Table-1 and Table-2.

**Supply Air Pressure:**

**Below 16 psig,** Operates at summer setpoint.

**Above 25 psig,** Operates at winter setpoint.

**Maximum Air Pressure:** 30 psig.

**Main Air Consumption:** See Table-1 and Table-2.

**Calibration Point:** See Table-1 and Table-2.

**Summer/Winter Indexing:** Remote, by change in main air pressure.

**Setpoint Adjustment:** Serrated thumbwheel.

**Construction:**

**Mechanical Components,** Die cast aluminum, stainless steel, and glass-filled nylon.

**Diaphragm,** Fabric-reinforced Neoprene.

**Air Lines,** Connect to thermostat nipples with spring-reinforced plastic tubes.

**Branch Connections,** Equipped with internal filters.

## Environment

**Humidity:** 5 to 95% relative humidity, non-condensing.

**Locations:** NEMA Type 1.

## ORDERING DATA

**Table-1 Model Chart — Thermostats.**

Wholesale Number	Replaces Model	Action	Setpoint Range	Calibration Point	Throttling Range	Air Consumption	Description
2218-132	T32-301	RA @ 16 psig DA @ 25 psig	55 to 85 °F (13 to 29 °C)	12 psig branch line pressure	Adjustable 2 to 12 °F (1 to 7 °C)	17 scim @ 16 psig 30 scim @ 25 psig	Includes (2) 1/4" x 3/16" barbed couplings, 20-693 tubing, 20-714 wall plate, 20-711 mounting plate, and mounting screws.
2218-142 <sup>a</sup>	T32-3011						
2218-133	T33-301	DA @ 16 psig RA @ 25 psig					
2218-134	T32-321	RA @ 13 psig DA @ 18 psig					
2218-301 <sup>ab</sup>	T34-3011	RA @ 16 psig (summer) DA @ 25 psig (winter)	Winter = 44 to 74 °F (7 to 23 °C) Summer = 76 to 85 °F (24 to 29 °C)	9 psig branch line pressure	Fixed 4 °F (2 °C) Nominal 2 °F (1 °C)	30 scim @ 16 psig 43 scim @ 25 psig	

<sup>a</sup> These models include factory-installed 20-712 dial stop kits.

<sup>b</sup> Special energy-conservation model. Use of 21-928 blank cover with this model is suggested.

**Table-2 Model Chart — Uni-Kits®.**

Wholesale Number	Replaces Model	Action	Setpoint Range	Calibration Point	Throttling Range	Air Consumption	Description
2218-532 <sup>a</sup>	T32-3011	RA @ 16 psig DA @ 25 psig	55 to 85 °F (13 to 29 °C)	12 psig branch line pressure	Adjustable 2 to 12 °F (1 to 7 °C)	17 scim @ 16 psig 30 scim @ 25 psig	Includes thermostat with stops, 21-933 full dial cover with blank cover conversion, and 22-022 conversion kit.
2218-534 <sup>ab</sup>	T34-3011		Winter = 44 to 74 °F (7 to 23 °C) Summer = 76 to 85 °F (24 to 29 °C)	9 psig branch line pressure	Fixed 4 °F (2 °C) Nominal 2 °F (1 °C)	30 scim @ 16 psig 43 scim @ 25 psig	
2218-632	T32-301		55 to 85 °F (13 to 29 °C)	12 psig branch line pressure	Adjustable 2 to 12 °F (1 to 7 °C)	17 scim @ 16 psig 30 scim @ 25 psig	Includes thermostat, 22-1033 full dial cover with blank cover conversion, and 22-023 conversion kit.

<sup>a</sup> These models include factory-installed 20-712 dial stop kits.

<sup>b</sup> Special energy-conservation model. Use of 21-928 blank cover with this model is suggested.

**Table-3 Covers.**

Wholesale Number	Replaces Model	Color	Material	Dial Markings	Setpoint Adjustment	Thermometer
21-923	C1-42	Satin Chrome	Metal	55 to 85 °F	Yes	No
22-923	C1-46		Plastic			
22-823	C1-47					
22-1023	C1-48	Euro-white				
21-928 <sup>a</sup>	C2-42	Satin Chrome	Metal	Blank	Concealed	
22-928 <sup>a</sup>	C2-46		Plastic			
22-828 <sup>a</sup>	C2-47	Beige				
22-1028 <sup>a</sup>	C2-48	Euro-white				
21-933	C3-42	Satin Chrome	Metal	55 to 85 °F	Yes	Yes (External)
22-933	C3-46		Plastic			
22-833	C3-47					
22-1033	C3-48	Euro-white				
21-939 <sup>a</sup>	C4-42	Satin Chrome	Metal	55 to 85 °F	Concealed	
22-939 <sup>a</sup>	C4-46		Plastic			
22-839 <sup>a</sup>	C4-47	Beige				
22-1039 <sup>a</sup>	C4-48	Euro-white	10 to 30 °C			

**Table-3 Covers. (Continued)**

Wholesale Number	Replaces Model	Color	Material	Dial Markings	Setpoint Adjustment	Thermometer
21-943	C5-42	Satin Chrome	Metal	Cooler - Warmer	Yes	No
22-943	C5-46		Plastic			
22-843	C5-47	Metal				
22-1043	C5-48		Euro-white			
21-948	C6-42	Satin Chrome	Plastic			
22-948	C6-46					
22-848	C6-47	Beige				
22-1048	C6-48	Euro-white				
21-957 <sup>a</sup>	C11-42	Satin Chrome	Metal	None	Concealed	Yes (External)
22-957 <sup>a</sup>	C11-46		Plastic			
22-857 <sup>a</sup>	C11-47	Beige				
22-1057 <sup>a</sup>	C11-48	Euro-white				
21-960 <sup>a</sup>	C14-42	Satin Chrome	Metal	Blank	Concealed	Yes (Internal)
22-960 <sup>a</sup>	C14-46		Plastic			
22-860 <sup>a</sup>	C14-47	Beige				
22-1060 <sup>a</sup>	C14-48	Euro-white				
2890-010 <sup>a</sup>	Kit	Satin Chrome	Metal	55 to 85 °F or Blank	Yes or Concealed	No
2890-011 <sup>a</sup>	Kit		Plastic			
2890-012 <sup>a</sup>	Kit	Beige				
2890-013 <sup>a</sup>	Kit	Euro-white	10 to 30 °C or Blank			

<sup>a</sup> Thermostat covers with concealed setpoint adjustment, and thermostat cover kits include setpoint adjustment cover 21-800 (black) or 21-801 (Euro-white).

**Table-4 Accessories.**

Wholesale Number	Replaces Model	Description
20-676	10-18	Aspirating box, stainless steel
20-695	10-15	Aspirating box, satin finish
20-707	10-53	Metal thermostat guard
20-712	10-59	Internal stop kit
20-715	10-62	Clear cover thermostat guard
20-850	—	Thermostat mounting plate
20-881	N2-4	Thermostat calibration wrench
21-473	10-73	Drywall mounting bracket
21-800	10-72	Setpoint adjustment cover (black)
21-801	10-81-48	Setpoint adjustment cover (Euro-white)
21-876	10-76	Opaque cover thermostat guard
22-022	—	Thermostat conversion kit
22-023	—	Thermostat conversion kit
22-138	MCS-GA	Branch tap gauge adaptor
900-002	—	Thermostat calibration kit

**TYPICAL APPLICATIONS  
(Piping Diagram)**

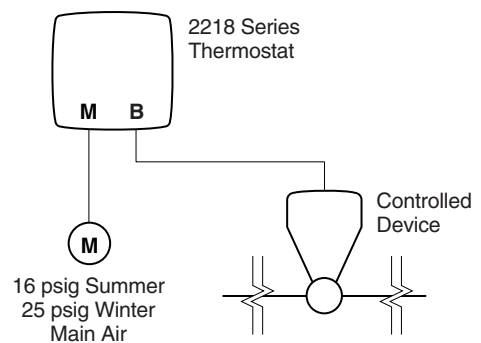

Figure-1 Typical Application.

# INSTALLATION

## Inspection

Inspect the package for damage. If damaged, notify the appropriate carrier immediately. If undamaged, open the package and inspect the device for obvious damage. Return damaged products.

## Requirements

- Tools (not provided):
  - Appropriate screwdriver for mounting the thermostat
  - 20-881 Thermostat calibration and cover screw wrench (or 1/16" and 1/4" hex wrenches)
- Training: Installer must be a qualified, experienced technician
- Appropriate accessories
- Piping diagrams

## Location

### Caution:

- Do not locate the thermostat near sources of heat or cold, such as lamps, motors, sunlight, or concealed ducts or pipes. Doing so will affect the accuracy of the thermostat.
- Avoid installing the thermostat on outside walls. If such a location is necessary, mount the thermostat on an insulated back plate (accessory item).
- Mount thermostats *only after the wall surfaces have been finished.*

Locate the thermostat where it will be exposed to an unrestricted circulation of air, which represents the average temperature of the controlled space.

## Mounting

### Standard Mounting Options

1. Mount the thermostat according to the applicable figure (Figure-2 through Figure-8). See Figure-11 for mounting dimensions.

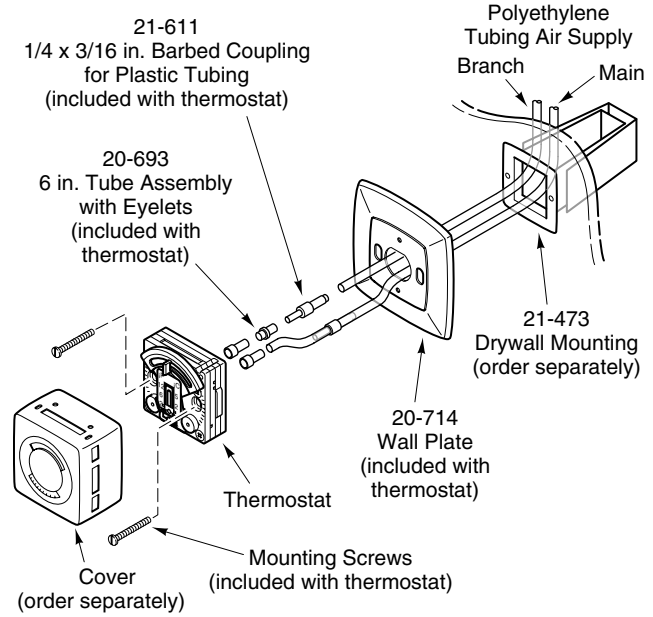

Figure-2 Flush Mounting of Thermostat, Using Drywall Mounting Bracket.

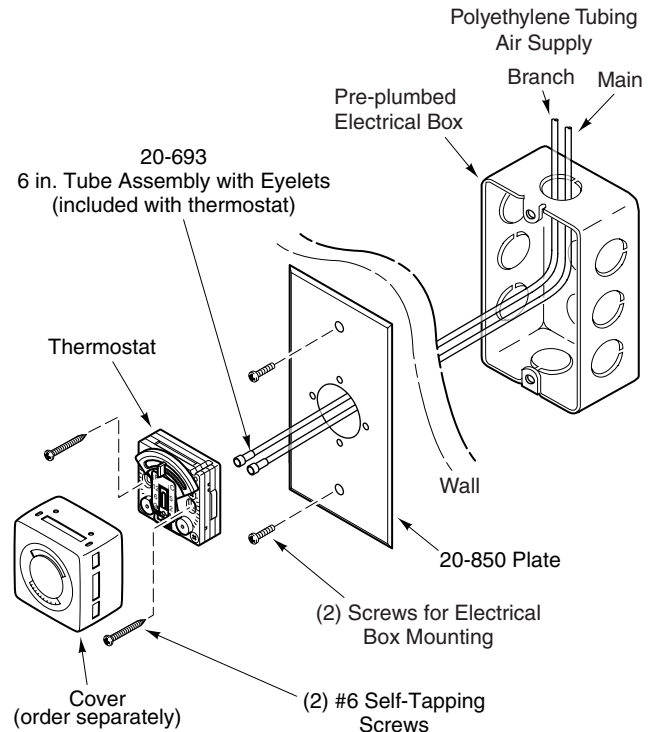

Figure-3 Flush Mounting of Thermostat, Using 20-850 Plate and Pre-Plumbed Electrical Box.

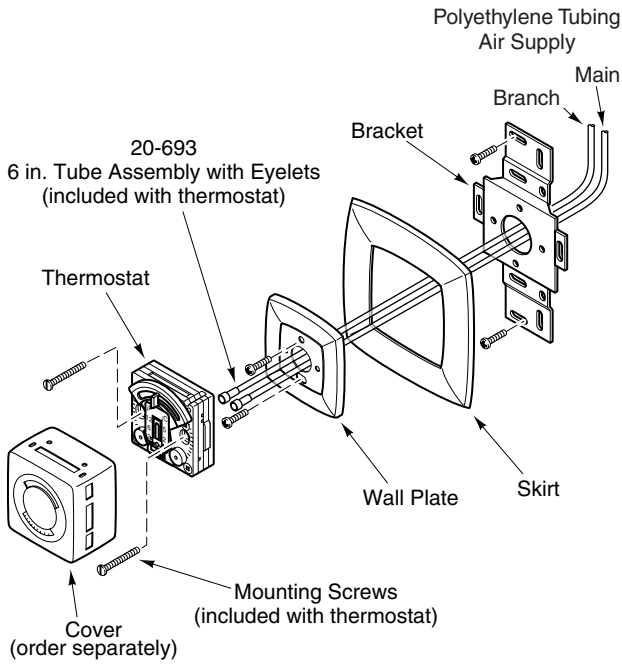

Figure-4 Thermostat Mounted with 22-022 Conversion Kit, Using Wall Plate and Skirt, to Replace Competitive Thermostats.

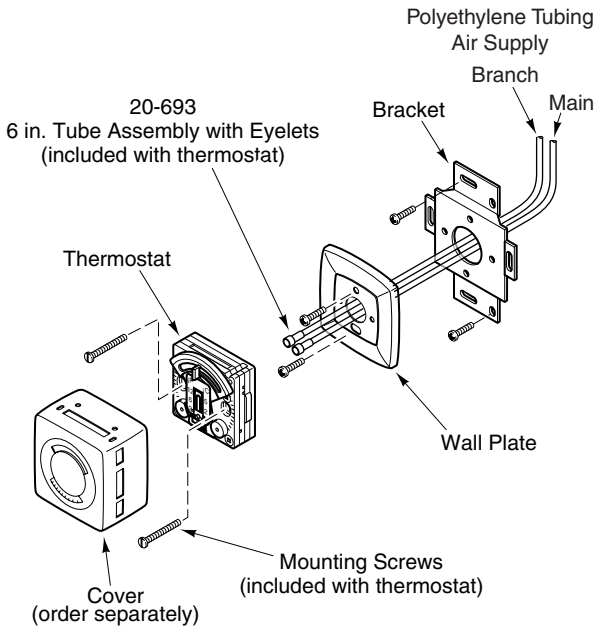
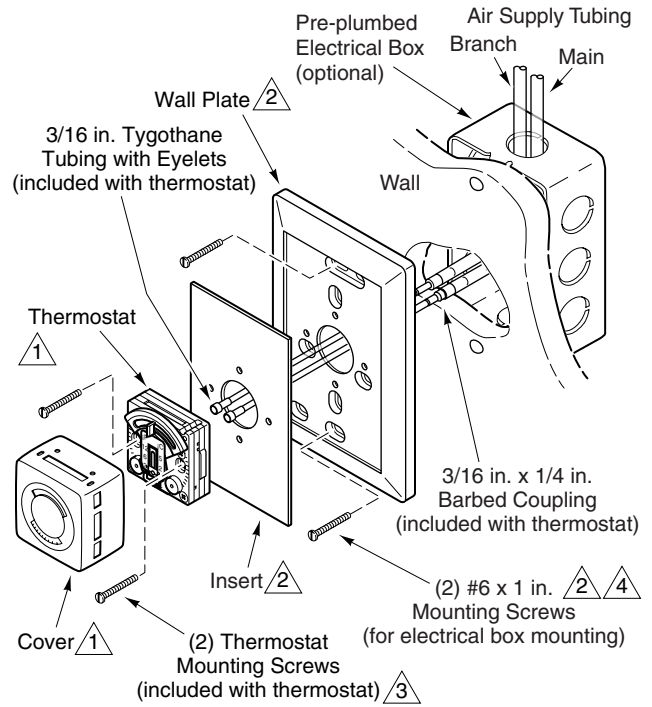

Figure-5 Thermostat Mounted with 22-022 Conversion Kit, Using Wall Plate Only, to Replace Competitive Thermostats.



- 1 The pneumatic thermostat replacement kit 2218-632 includes a thermostat, a 22-1033 Euro-white cover, and a 22-023 thermostat conversion kit.
- 2 Provided in the 22-023 thermostat conversion kit.
- 3 Optionally, the thermostat may be mounted with the #6 x 1 in. self-tapping screws provided in the 22-023 kit.
- 4 Use the #8 x 1 in. mounting screws provided in the 22-023 kit when mounting the wall plate directly to the wall, without an electrical box.

Figure-6 Thermostat Mounted with 22-023 Thermostat Conversion Kit.

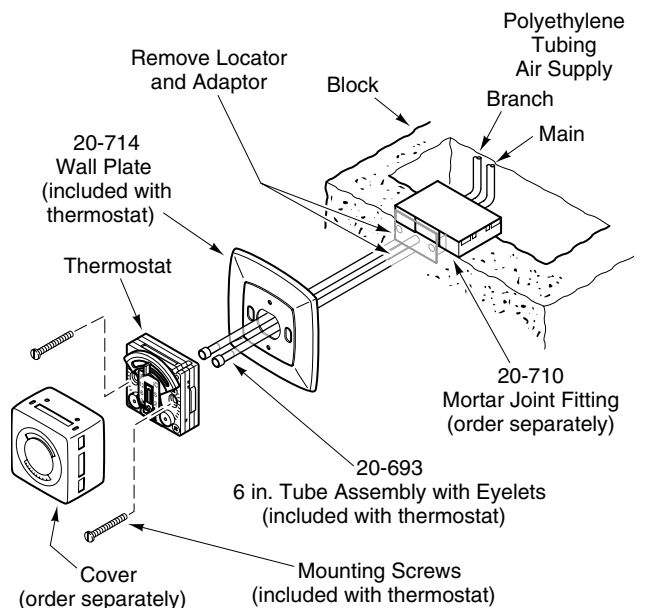

Figure-7 Thermostat Installation Using Pipehead in Masonry Wall.

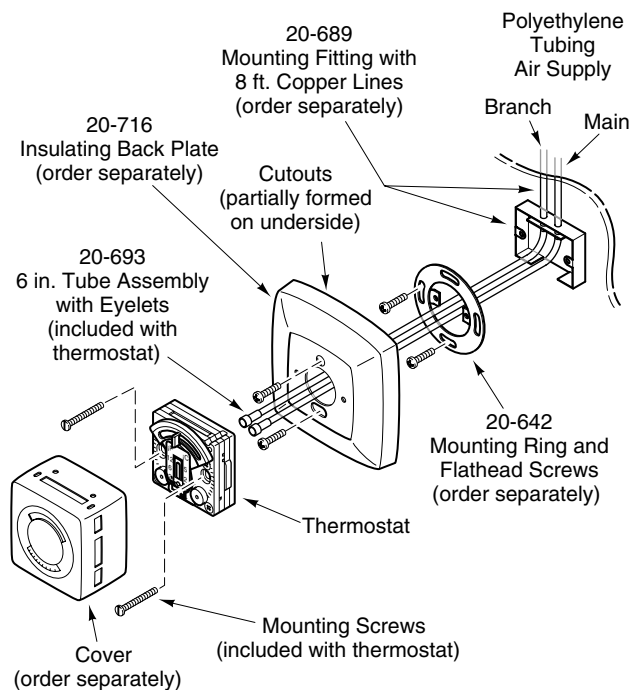

Figure-8 Surface Mounting of Thermostat, Pipehead Application.

### Optional Mounting

Eliminate the pipehead fitting by using the 22-022 thermostat conversion kit and the included instructions, plus the following:

**1/4" Plastic Air Lines:** Install the 1/4" barbed couplings into the air lines. Connect the tube assembly to the 3/16" end of these couplings.

**1/4" Copper Air Lines:** Solder the barbed couplings into the copper lines. The tube assembly can then be connected to the 3/16" end of the couplings.

## CALIBRATION

### Calibration of Single Bimetal Models

The 2218 series thermostats are factory calibrated with the throttling range set at 3 °F. They should not require calibration upon installation. However, if the throttling range is changed, or if limited summer control action at 8 psig main air pressure is required, recalibrate the thermostat as follows:

1. Remove the thermostat cover and install a 22-138 branch tap gauge adaptor into the branch pressure tap hole (Figure-9).
2. Measure the ambient temperature with an accurate thermometer. This temperature *must be within the range of the thermostat*. Take care not to breathe on, or place a hand near the bimetals, as this will result in an inaccurate reading.
3. Move the setpoint adjustment to the measured ambient temperature, using the internal setpoint indicator.

### Standard Calibration

1. Taking care not to breathe on, or place the hand near the bimetal, use a 20-881 thermostat wrench (1/16" hex wrench) to turn the reverse acting calibration screw until the branch line pressure indicates 12 psig. Clockwise rotation increases the branch line pressure. Counterclockwise rotation decreases the branch line pressure.
2. Raise the main air pressure to 25 psig.
3. Turn the direct acting calibration screw until the test gauge indicates 12 psig. Clockwise rotation decreases the branch line pressure. Counterclockwise rotation increases the branch line pressure.

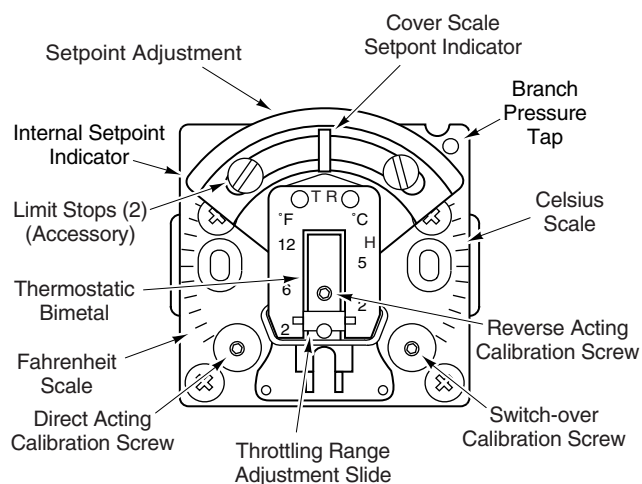

Figure-9 Single Bimetal Thermostat Calibration Features and Limit Stop Accessory.

### Special Calibration — 8 psig Summer Control

1. Set the main air pressure to 8 psig.
2. Taking care not to breathe on, or place the hand near the bimetal, use a 20-881 thermostat wrench (1/16" hex wrench) to turn the reverse acting calibration screw until the branch line pressure indicates 6 psig. Clockwise rotation increases the branch line pressure. Counterclockwise rotation decreases the branch line pressure.
3. Raise the main air pressure to 25 psig.
4. Turn the direct acting calibration screw until the test gauge indicates 6 psig. Clockwise rotation decreases the branch line pressure. Counterclockwise rotation increases the branch line pressure.

## Switch Over Point Adjustment

If necessary, adjust the switch point as follows:

---

### Note:

- The switch point adjustment requires changes to the main air pressure, which could affect other parts of the system. This adjustment should instead be made on a test bench at which a variable main air supply is available.
- Install a test gauge into the branch line, so that this pressure can be measured while making the switch point adjustment.

1. Set the main air pressure to the desired switch over point.
2. Move the setpoint adjustment to its farthest clockwise position.
3. Use a 20-881 thermostat wrench (1/16" hex wrench) to turn the switch over calibration screw, 1/8 turn at a time, until the branch pressure just drops to 0 psig. This sets the switch over point.
4. Recalibrate the thermostat according to the instructions in Standard Calibration or Special Calibration, as applicable.
5. Reinstall the thermostat cover and set the thermostat to the desired setpoint.

## Calibration of Dual Bimetal Models

The 2218-301 thermostat is factory calibrated and should not require calibration upon installation. However, if the summer or winter setpoint requires calibration, or if the switch point needs to be raised or lowered, recalibrate the thermostat as follows:

1. Remove the thermostat cover and install a 22-138 branch tap gauge adaptor and a suitable 0 to 30 psig gauge into the branch pressure tap hole (Figure-10).
2. Measure the ambient temperature with an accurate thermometer. This temperature *must be within the range of the thermostat*. Take care not to breathe on, or place a hand near the bimetals, as this will result in an inaccurate reading.

### Summer Setpoint Calibration

1. Position the summer setpoint cam to the measured ambient temperature (Figure-10).
2. Set the main air pressure to 16 psig.
3. Adjust the summer calibration screw, using a 20-881 thermostat wrench (1/16" hex wrench), until the branch tap gauge reads  $9 \pm 1$  psig. Clockwise rotation increases the branch line pressure. Counterclockwise rotation decreases the branch line pressure.

### Winter Setpoint Calibration

1. Increase the main air pressure to 25 psig.
2. Using a 20-881 thermostat wrench (1/16" hex wrench), rotate the winter calibration screw until the branch tap gauge reads  $9 \pm 1$  psig. Clockwise rotation increases the branch line pressure. Counterclockwise rotation decreases the branch line pressure.

3. The winter setpoint is in calibration when the winter setpoint dial indicates the ambient temperature within  $\pm 2$  °F. If not, adjust the winter setpoint as follows:
  - a. Rotate the winter setpoint screw until the dial gently contacts its stop. Clockwise rotation increases the ambient temperature reading, and counterclockwise rotation decreases the ambient temperature reading.
  - b. Continue rotating the setpoint screw approximately 1/8 turn, slipping the screw inside the dial.
  - c. Turn the setpoint screw back and check for  $9 \pm 1$  psig branch air pressure, with the dial indicating the ambient temperature within  $\pm 2$  °F.
  - d. Repeat steps a, b, and c, as necessary, until winter setpoint calibration is obtained.
4. The winter setpoint screw may now be used to position the dial to the desired winter control point.

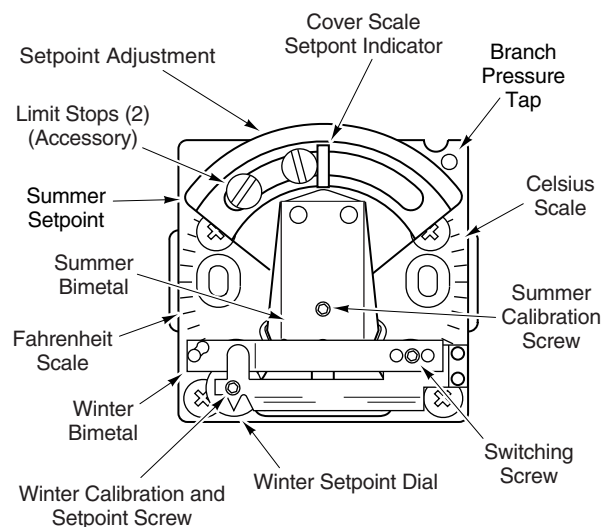

Figure-10 Dual Bimetal Thermostat Calibration Features and Limit Stop Accessory.

## Switch Over Point Adjustment

Adjust the switch over point as follows:

---

### Note:

- The switch point adjustment requires changes to the main air pressure, which could affect other parts of the system. This adjustment should instead be made on a test bench at which a variable main air supply is available.
- Install a test gauge into the branch line, so that this pressure can be measured while making the switch point adjustment.

1. Set the main air pressure to 15 psig.
2. Position the summer setpoint dial to 85 °F and the winter setpoint dial to 44 °F.
3. The branch tap gauge should read 15 psig, minimum. If not, recheck the summer setpoint calibration.

4. Slowly increase the main air pressure until the branch tap gauge drops to 0 psig. This is the main air pressure at which the thermostat switches from summer control to winter control.
5. If the main air pressure at the switching point is less than 17 psig or greater than 21 psig, adjust the switching screw as follows, using a 20-881 thermostat wrench (1/16" hex wrench):
  - a. If the switching point is less than 17 psig, turn the switching screw 1/8 turn counterclockwise, to raise the switching point. Raise the main air pressure until the branch tap gauge reading drops to 0 psig (switching point). If the main air pressure at this point is still less than 17 psig, repeat this step, as necessary, until the switching point is obtained.
  - b. If the switching point is greater than 21 psig, turn the switching screw 1/8 turn clockwise, to lower the switching point. Lower the main air pressure until the branch tap gauge reading drops to 0 psig (switching point). If the main air pressure at this point is still greater than 21 psig, repeat this step, as necessary, until the switching point is obtained.

---

**Caution:** Do not force the calibrating screws. If the desired action is not obtained when the screw is rotated, check to be sure the direction of rotation is correct.

---

6. Reinstall the thermostat cover and set the thermostat to the desired setpoint.

### Concealed Adjustment

If concealment of the setpoint adjustment is required, install a 21-800 (black) or 21-801 (Euro-white) setpoint adjustment cover as follows:

1. Remove the thermostat cover.
2. Insert the adjustment cover through the slot at the top of the cover and bend the tangs outward on the inside of the cover.
3. Reinstall the cover onto the thermostat.

### Internal Stop Kit (Accessory)

The internal stop kit, model 20-712, consists of two screws and two nuts (Figure-9 and Figure-10). Install this kit as follows:

1. Move the setpoint adjustment to one extreme limit.
2. Place a nut in the depression in the top plate and move the adjustment cam over the nut, to where the slot in the cam exposes the threads of the nut.
3. Thread a stop screw into the nut far enough to allow the stop to slide in the slot. Repeat on the other side.

4. Move the setpoint adjustment to the desired temperature, using the internal setpoint indicator.
5. Slide the stops to the desired limits and tighten both screws.

## MAINTENANCE

The thermostat requires no maintenance.

Regular maintenance of the total system is recommended to assure sustained, optimum performance.

## FIELD REPAIR

None. Replace an inoperative thermostat with a functional unit.

## DIMENSIONAL DATA

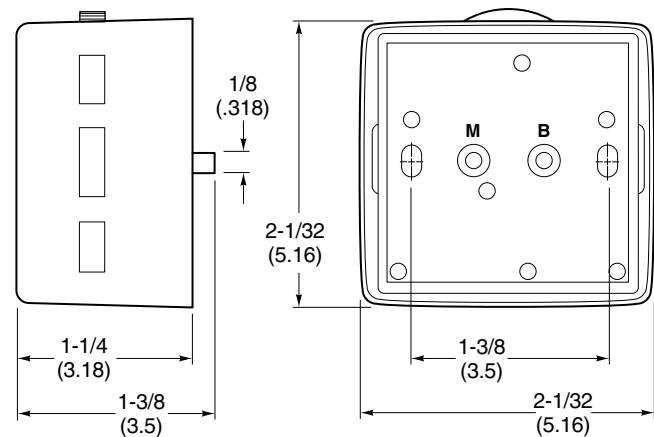

Dimensions are in inches (mm).

Figure-11 Mounting Dimensions.